

OWNER'S GUIDE &

INSTALLATION INSTRUCTIONS

Retractable TRIDUCER® Multisensor with Valve

Model DST800V

U.S. Patents: 4,898,029; Re-issue 33, 982; 6,904,798 B2.
Australian Patent 605,281. Canadian Patent 1,313,775. Japanese Patent 1851014

IMPORTANT: Please read the instructions completely before proceeding with the installation. These instructions supersede any other instructions in your instrument manual if they differ.

CAUTION: NEVER USE SOLVENTS!

Cleaners, fuel, paint, sealants, and other products may contain strong solvents, such as acetone, which attack many plastics greatly reducing their strength.

Applications

- **Plastic** housing recommended for fiberglass or metal hulls only. *Never* install a plastic housing in a wood hull since swelling of the wood can possibly fracture the plastic.
- **Bronze** housing recommended for fiberglass or wood hulls. *Never* mount a bronze housing in an aluminum hull because electrolytic corrosion will occur.
- **Stainless steel** housing compatible with all hull materials. Recommended for aluminum hulls to prevent electrolytic corrosion *provided the stainless steel housing is isolated from the metal hull.*
- *Never* install a metal housing in a vessel with a positive ground system.

Tools & Materials

Water-based antifouling paint (**MANDATORY IN SALT WATER**)

Safety goggles

Dust mask

Electric drill with 10mm (3/8") or larger chuck capacity

Drill bit: 3mm or 1/8"

Hole saw: 51mm or 2" (plastic or bronze housing)

57mm or 2-1/4" (stainless steel housing in a metal hull)

Sandpaper

Mild household detergent or weak solvent (such as alcohol)

File (installation in a metal hull)

Marine sealant (suitable for below waterline)

Additional washer [for aluminum hull less than 6mm (1/4") thick]

Slip-joint pliers (installing a bronze housing)

Zip-ties

Installation in a cored fiberglass hull (see page 3):

Hole saw for hull interior: 60mm or 2-3/8"

Fiberglass cloth and resin

or Cylinder, wax, tape, and casting epoxy

Fairing

Caution: *Never use a fairing with a plastic housing; the protruding multisensor would be vulnerable to damage from impact.*

Record the information found on the cable tag for future reference.

Part No. _____ Date _____ Frequency _____ kHz

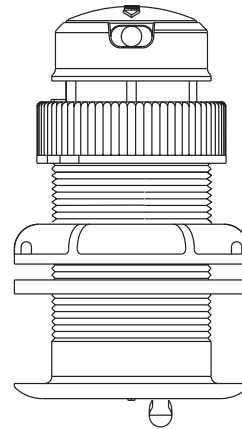

DST800V
plastic
low profile
P617 housing

Pretest

Connect the multisensor to the instrument and spin the paddlewheel. Check for a speed reading and the approximate air temperature. If there are no readings or they are inaccurate, check all the connections and repeat the test. If there are still no reading or they are inaccurate, return the product to the place of purchase.

Antifouling Paint

Aquatic growth can accumulate rapidly on the multisensor's surface reducing performance within weeks. Surfaces exposed to salt water *must* be coated with antifouling paint. Use **WATER-BASED** antifouling paint only. *Never* use ketone-based paint, since ketones can attack many plastics possibly damaging the multisensor.

It is easier to apply antifouling paint before installation, but allow sufficient drying time. Reapply paint every 6 months or at the beginning of each boating season. Paint the following surfaces (see Figure 1):

- Outside wall of the insert below the lower O-ring
- Paddlewheel cavity
- Paddlewheel
- Exposed end of the insert
- Exterior lip of the housing
- Bore of the housing up 30mm (1-1/4")
- Blanking plug below the lower O-ring including the exposed end

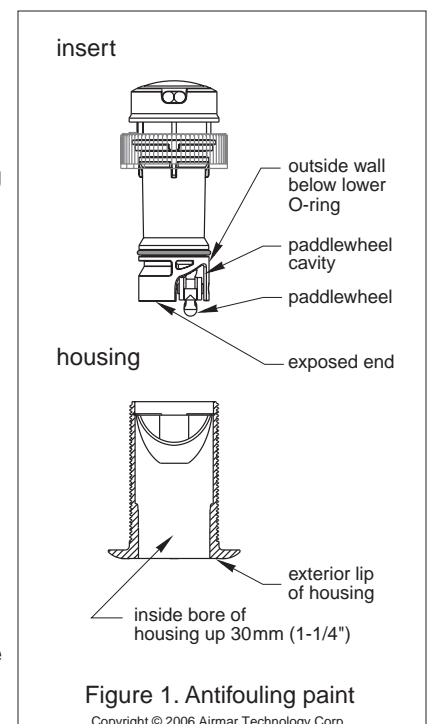
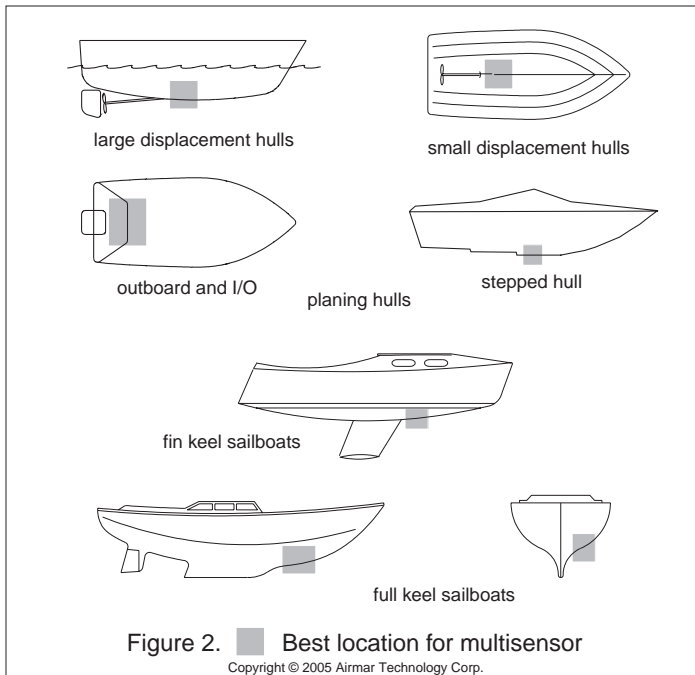

Figure 1. Antifouling paint

Copyright © 2006 Airmar Technology Corp.



Mounting Location

- The water flowing across the hull *must* be smooth with a minimum of bubbles and turbulence (especially at high speeds).

Caution: *DO NOT MOUNT near water intake or discharge openings, or behind strakes, fittings, or hull irregularities.*

- The multisensor *must* be continuously immersed in water.
- The transducer beam *must* be unobstructed by the keel or propeller shaft(s).
- Choose a location away from interference caused by power and radiation sources such as: the propeller(s) and shaft(s), other machinery, other echosounders, and other cables. The lower the noise level, the higher the echosounder gain setting that can be used.
- Choose a location with a minimum deadrise angle, so the transducer beam will be aimed at the bottom.
- Choose an accessible spot inside the vessel with adequate headroom for the height of the housing, tightening the nuts, and removing the insert. Allow a minimum of 280mm (11").

Hull Types (see Figure 2)

- Displacement hull powerboats**—Locate amidships near the centerline. The starboard side of the hull where the propeller blades are moving downward is preferred.
- Planing hull powerboats**—Mount well aft, on or near the centerline, and *well inboard of the first set of lifting strakes* to insure that the multisensor will be in contact with the water at high speeds. The starboard side of the hull where the propeller blades are moving downward is preferred.
 - Outboard and I/O**—Mount just forward of the engine(s).
 - Inboard**—Mount well ahead of the propeller(s) and shaft(s).
 - Stepped hull**—Mount just ahead of the first step.
- Boat capable of speeds above 25kn (29MPH)**—Review the installation location and operating results of similar boats before proceeding.
- Fin keel sailboats**—Mount on or as close as possible to the centerline and forward of the fin keel 300–600mm (1–2').
- Full keel sailboats**—Locate amidships and away from the keel at the point of minimum deadrise.

Installation

Cored fiberglass hull—Follow separate instructions on page 3.

Hole Drilling

Warning: *Always wear safety goggles and a dust mask.*

- Drill a 3mm or 1/8" pilot hole from inside the hull. If there is a rib, strut or other hull irregularity near the selected mounting location, drill from the outside.
 - Using the appropriate size hole saw, cut a hole from outside the hull. Sand and clean the area around the hole, inside and outside, to ensure that the sealant will adhere properly to the hull. If there is any petroleum residue inside the hull, remove it with either mild household detergent or a weak solvent (alcohol) before sanding.
- Metal hull**—Remove all burrs with a file and sandpaper.

Bedding

Caution: *A stainless steel housing must be isolated from a metal hull to prevent electrolytic corrosion.*

Apply a 2mm (1/16") thick layer of marine sealant around the lip of the housing that contacts the hull and up the sidewall of the housing. The sealant *must* extend 6mm (1/4") higher than the combined thickness of the hull, the washer(s), and the hull nut (see Figure 3). This will ensure there is sealant in the threads to seal the hull and to hold the hull nut securely in place.

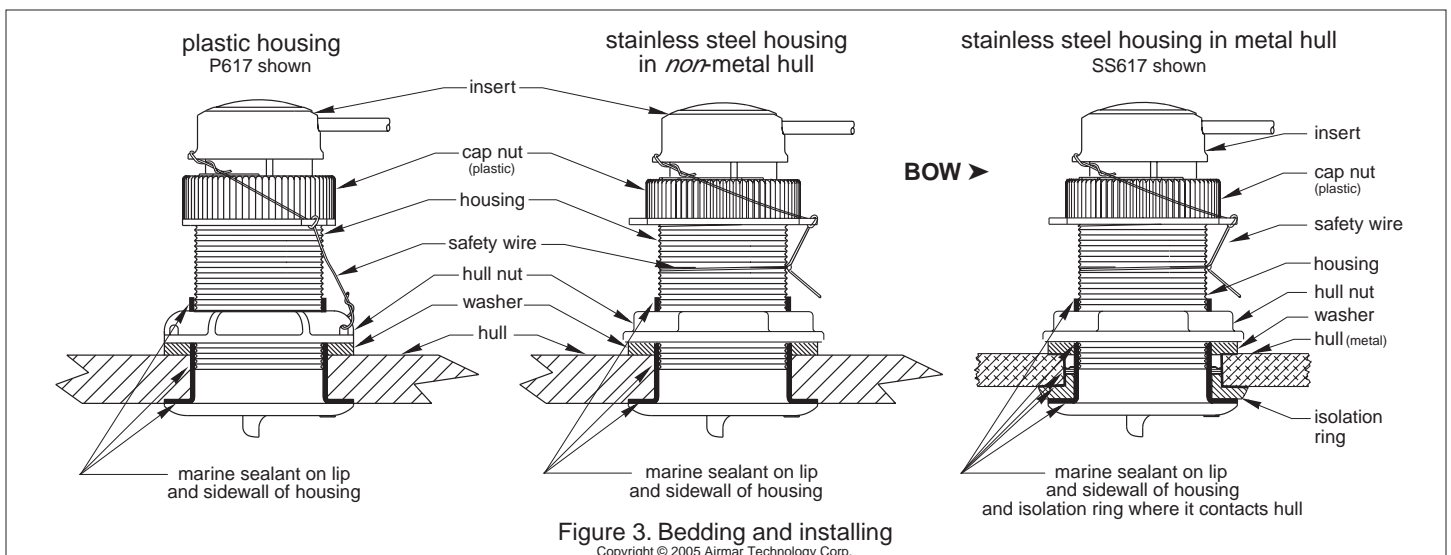

Stainless steel housing in a metal hull—To isolate the stainless steel housing from the metal hull, slide the isolation ring onto the housing. Apply *additional* sealant to the surfaces of the ring that will contact the hull, filling any cavities in and around the ring.

Installing

Caution: *Never pull, carry, or hold the multisensor by the cable as this may sever internal connections.*

1. From outside the hull, push the housing into the mounting hole using a twisting motion to squeeze out excess sealant (see Figure 3). *Align the arrow on the lip of the housing to point forward toward the bow.* If the multisensor is not installed on the centerline of the boat, angle the housing slightly toward the centerline to align it with the water flow.

2. From inside the hull, slide the washer onto the housing.
Aluminum hull less than 6 mm (1/4") thick—Use an additional rubbery, fiberglass, or plastic washer. *Never* use bronze since electrolytic corrosion will occur. *Never* use wood since it will swell, possibly fracturing the plastic housing.

Warning: Stainless steel housing in a metal hull only—*Be sure the washer contacts the hull. Do not tighten the hull nut with the washer against the isolation ring, as the housing will not be firmly installed. If necessary, sand the isolation ring until the washer rests against the hull.*

3. Screw the hull nut in place *being sure* the arrow on the lip of the housing is still positioned forward toward the bow.

Wood hull—Allow for the wood to swell.

Plastic hull nut—**Hand-tighten** only. *Do not* over-tighten.

Metal hull nut—Tighten with slip-joint pliers.

Cored Fiberglass Hull—*Do not* over-tighten, crushing the hull.

4. Remove any excess marine sealant on the outside of the hull to ensure smooth water flow over the multisensor.

Warning: The Yellow O-ring must be in place. All O-rings must be intact and well lubricated to make a watertight seal.

5. After the marine sealant cures, inspect the O-rings on the insert (replace if necessary) and lubricate them with the silicone lubricant supplied. Also lubricate the interior bore of the housing above the lip of the valve.

Warning: *Be sure the insert is fully inserted into the housing, and the cap nut is screwed on completely.*

6. Slide the paddlewheel insert into the housing with the *arrow on the top pointing forward toward the bow.* Screw the cap nut several turns until the threads are engaged. The arrow on the top of the insert, the cable exit, and the arrow on the lip will all be aligned. Continue to tighten the cap nut. *Be careful* not to rotate the housing and disturb the sealant. **HAND-TIGHTEN** only. *Do not* over tighten.

Warning: Housing WITHOUT a valve—*To create a watertight seal in a housing that does NOT have a valve, the insert must have a BLACK O-ring near the top. Use Replacement O-ring kit 20-519-01 and follow the instructions supplied.*

Warning: *Always attach the safety wire to prevent the insert from backing out in the unlikely event that the cap nut fails or is screwed on incorrectly.*

7. Attach the safety wire.

Plastic housing—Attach the safety wire to one eye in the hull nut. Keeping the wire taut throughout, lead the wire in a counterclockwise direction and thread it through one eye in the cap nut. Thread the wire through the eye a second time. Then lead the wire through the eye in the insert. Twist the wire securely to itself.

Metal housing—Wrap one end of the safety wire tightly around the housing and twist it together with the long end. Keeping the wire taut throughout, lead the wire straight up and through one eye in the cap nut. Thread the wire through the eye a second time. Then lead the wire counterclockwise and through the eye in the insert. Twist the wire securely to itself.

Caution: *If your multisensor came with a connector, do not remove it to ease cable routing. If the cable must be cut and spliced, use Airmar's splash-proof Junction Box No. 33-035 and follow the instructions provided. Cutting the cable or removing the waterproof connector, except when using Airmar's junction box, will void the multisensor warranty.*

8. Route the cable to the instrument *being careful* not to tear the cable jacket when passing it through the bulkhead(s) and other parts of the boat. To reduce electrical interference, separate the multisensor cable from other electrical wiring and the engine. Coil any excess cable and secure it in place with zip-ties to prevent damage.
9. Refer to the instrument owner's manual to connect the multisensor to the instrument.

Checking for Leaks

Warning: *DO NOT leave the boat in the water unchecked for several days.*

When the boat is placed in the water, **immediately** check the thru-hull multisensor for leaks. Note that very small leaks may not be readily observed. *Do not* leave the boat in the water for more than 3 hours before checking it again. If there is a small leak, there may be considerable bilge water accumulation after 24 hours. If a leak is observed, repeat "Bedding" and "Installing" **immediately** (see pages 2 and 3).

Installation in a Cored Fiberglass Hull

The core (wood or foam) *must* be cut and sealed carefully. The core *must* be protected from water seepage, and the hull *must* be reinforced to prevent it from crushing under the hull nut allowing the housing to become loose.

Warning: *Always wear safety goggles and a dust mask.*

1. Drill a 3mm or 1/8" pilot hole from inside the hull. If there is a rib, strut, or other hull irregularity near the selected mounting location, drill from the outside. (If the hole is drilled in the wrong location, drill a second hole in a better location. Apply masking tape to the outside of the hull over the incorrect hole and fill it with epoxy.)
2. Using a 51 mm or 2" hole saw, cut the hole from outside the hull through the *outerskin* only (see Figure 4).
3. From inside the hull, use a 60mm or 2-3/8" hole saw to cut through the *innerskin* and most of the core. The core material can be very soft. Apply only light pressure to the hole saw after cutting through the inner skin to avoid accidentally cutting the *outer skin*.

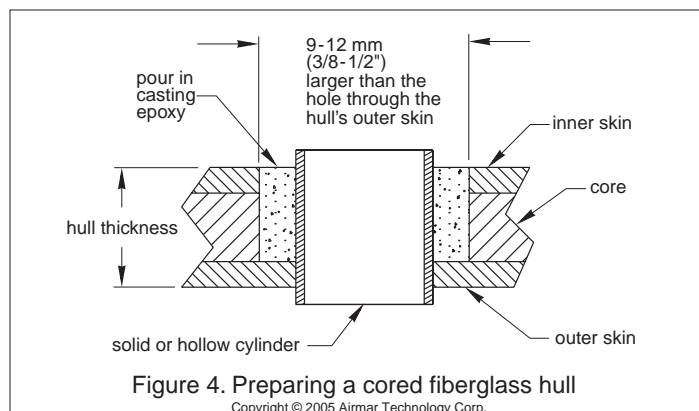

Figure 4. Preparing a cored fiberglass hull

Copyright © 2005 Airmar Technology Corp.

- Remove the plug of core material so the *inside* of the outer skin and the inner core of the hull are fully exposed. Sand and clean the inner skin, core, and the outer skin around the hole.

Caution: Completely seal the hull to prevent water seepage into the core.

- If you are skilled with fiberglass, saturate a layer of fiberglass cloth with a suitable resin and lay it inside the hole to seal and strengthen the core. Add layers until the hole is the correct diameter.
- Alternatively, a hollow or solid cylinder of the correct diameter can be coated with wax and taped in place. Fill the gap between the cylinder and hull with casting epoxy. After the epoxy has set, remove the cylinder.
- Sand and clean the area around the hole, inside and outside, to ensure that the marine sealant will adhere properly to the hull. If there is any petroleum residue inside the hull, remove it with either mild household detergent or a weak solvent (alcohol) before sanding.
- Proceed with "Bedding" and "Installing" (see pages 2 and 3).

Operation & Maintenance

How the Valve Works

WARNING: THE VALVE IS NOT A WATERTIGHT SEAL!
Always use the insert or the blanking plug secured with the safety wire for a watertight seal.

The multisensor incorporates a self-closing valve which minimizes the flow of water into the boat when the insert is removed. The curved flap valve is activated by both a spring and water pressure. Water pushes the flap valve upward to block the opening, so there is no gush of water into the boat.

Using the Blanking Plug

To protect the paddlewheel, use the blanking plug:

- When the boat will be kept in salt water for more than a week.
- When the boat will be removed from the water.
- When aquatic growth buildup on the paddlewheel is suspected due to inaccurate readings from the instrument.

Warning: The O-rings must be intact and well lubricated to make a watertight seal.

- On the blanking plug, inspect the O-rings (replace if necessary) and lubricate them with the silicone lubricant supplied or petroleum jelly (Vaseline®) (see Figure 5).
- Remove the insert from the housing by removing the safety wire and unscrewing the cap nut (see Figure 3). This will jack out the insert.
- Grasp the insert and remove it with a slow pulling motion. Slide the blanking plug into the housing.

Note: In the very unlikely event that the valve breaks, replace the housing the next time the boat is hauled.

Warning: Be sure the blanking plug is fully inserted into the housing, and the cap nut is screwed on completely.

- Screw the cap nut several turns until the threads are engaged. Continue to tighten the cap nut. **HAND-TIGHTEN** only. Do not over-tighten.

WARNING: Always attach the safety wire to prevent the blanking plug from backing out in the unlikely event that the cap nut fails or is screwed on incorrectly.

- Reattach the safety wire.

Winterizing

After the boat has been hauled for winter storage, remove the blanking plug to let the water drain away before reinserting it. This will prevent any water from freezing around the blanking plug and possibly cracking it.

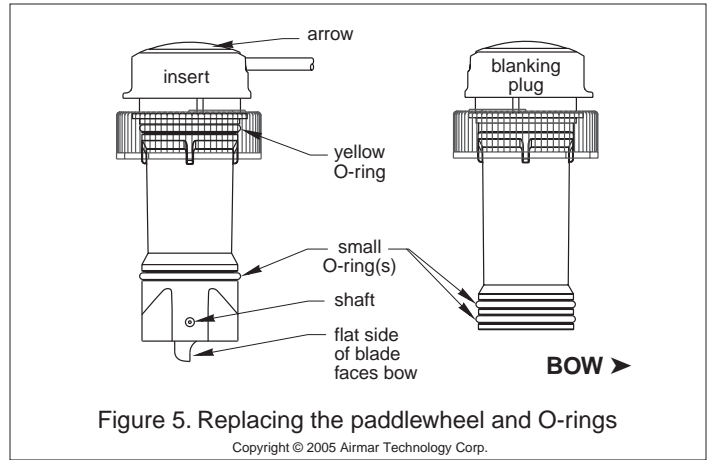

Figure 5. Replacing the paddlewheel and O-rings

Copyright © 2005 Airmar Technology Corp.

Servicing the Insert

Aquatic growth can accumulate rapidly on the depth transducer's face and impede or freeze the paddlewheel's rotation reducing performance within weeks. Clean the insert with a Scotch-Brite® scour pad and mild household detergent, *being careful* to avoid scratching the depth transducer. If fouling is severe, remove the paddlewheel (see step #1 below). Lightly wet sand it with fine grade wet/dry paper.

The water lubricated paddlewheel bearings have a life of up to 5 years on low-speed boats [less than 10kn (11MPH)] and 1 year on high-speed vessels. Paddlewheels can fracture and shafts can bend due to impact with water borne objects and mishandling in boat yards. O-rings must be free of abrasions and cuts to ensure a watertight seal. Order a replacement Paddlewheel Kit No. 33-540-01.

- To remove the old paddlewheel shaft, grasp the end with small diagonal wire cutters and pull (see Figure 5).
- Place the new paddlewheel in the cavity with the flat side of the blade facing the same direction as the arrow on the top of the insert.
- Tap the new shaft into place until the end is flush with the outside wall of the insert.
- Install the yellow O-ring near the top of the insert. Install a small O-ring near the paddlewheel.
- Place the remaining two small O-rings near the bottom of the blanking plug.

Replacement Parts

Lost, broken, or worn parts should be replaced immediately. If you have purchased a plastic housing and have a wood hull or desire greater strength, purchase an Airmar metal housing. Obtain parts from your instrument manufacturer or marine dealer.

Gemeco (USA) Tel: 843.394.3565
Fax: 843.394.3736
email: sales@gemeco.com
Airmar Europe Tel: +45.45.81.04.18
Fax: +45.45.81.04.93
email: sales@airmareurope.com

Blanking Plug	Hull Nut or Isolation Ring	Paddlewheel, Shaft, O-rings	Housing, Nut & Washer <i>NO VALVE</i>
33-538-01	04-004 (plastic) 02-570-01 (stainless) 04-186-1 (isolation ring)	33-540-01	33-100 bronze low-profile 33-224-01 bronze counterbore 33-091-01 bronze flush 33-094-01 stainless low profile

Housing w/ Valve, Nut & Washer 33-510-01 (plastic, low profile, P617)

Multisensor Replacement—The information needed to order a replacement Airmar multisensor is printed on the cable tag. Do not remove this tag. When ordering, specify the part number, date, and frequency in kHz. For convenient reference, record this information on the top of page one.